



AIR COMMAND DENMARK - MIL AIM

Address: Herningvej 30
DK-7470 Karup J
Denmark

Telephone: +45 728 11516
AFTN: EKMCYOYX
E-mail: FKO-KTP-F-AIM@mil.dk
Internet: www.flv.dk/milaim

MIL AIP DENMARK

AIRAC Cycle: 2307
Eff. 13 JUL 2023
Amendment No. 248

This AIRAC AMDT contains the following changes:

GEN 0.4	Checklist updated.
GEN 0.5	Removed corrections due new ANC 1:250.000 CPH AREA chart.
EKKA ADC	Holding point added TWY P.
EKKA AOC-A 09R	Editorial, MAG. VAR.
EKKA PATC 27L	Editorial.
EKSP ADC	Editorial.
EKSP AOC-A 10L	Editorial, MAG. VAR.
EKSP AOC-A 28R	Editorial, MAG. VAR.

INSERT THE FOLLOWING PAGES:

GEN	
GEN 0.4-1/	13 JUL 2023
GEN 0.4-2	13 JUL 2023
GEN 0.4-3/	13 JUL 2023
GEN 0.4-4	13 JUL 2023
GEN 0.4-5	13 JUL 2023
GEN 0.5-3	13 JUL 2023

AD	
EKKA	
ADC	13 JUL 2023
AOC-A 09R	13 JUL 2023
PATC 27L	13 JUL 2023

EKSP	
ADC	13 JUL 2023
AOC-A 10L	13 JUL 2023
AOC-A 28R	13 JUL 2023

DESTROY THE FOLLOWING PAGES:

GEN	
GEN 0.4-1/	15 JUN 2023
GEN 0.4-2	15 JUN 2023
GEN 0.4-3/	15 JUN 2023
GEN 0.4-4	15 JUN 2023
GEN 0.4-5	15 JUN 2023
GEN 0.5-3	18 MAY 2023

AD	
EKKA	
ADC	23 MAR 2023
AOC-A 09R	24 FEB 2022
PATC 27L	24 FEB 2022

EKSP	
ADC	18 MAY 2023
AOC-A 10L	24 FEB 2022
AOC-A 10L	24 FEB 2022

END

BLANK

GEN 0.4 CHECKLIST OF AIP PAGES

PAGE	DATE	PAGE	DATE
GEN		2.5-5	11 AUG 2022
GEN0		2.6-1	24 FEB 2022
0.1-1	24 FEB 2022	2.6-2	24 FEB 2022
0.1-2	24 FEB 2022	2.6-3	24 FEB 2022
0.1-3	26 JAN 2023	2.7-1	01 DEC 2022
0.1-4	24 FEB 2022	2.7-2	01 DEC 2022
0.2-1	24 FEB 2022	2.7-3	01 DEC 2022
0.3-1	19 MAY 2022	2.7-4	01 DEC 2022
0.4-1	13 JUL 2023	2.7-5	01 DEC 2022
0.4-2	13 JUL 2023	2.7-6	01 DEC 2022
0.4-3	13 JUL 2023	2.7-7	01 DEC 2022
0.4-4	13 JUL 2023	2.7-8	01 DEC 2022
0.4-5	13 JUL 2023	2.7-9	01 DEC 2022
0.5-1	24 FEB 2022	2.7-10	01 DEC 2022
0.5-2	15 JUN 2023	2.7-11	01 DEC 2022
0.5-3	13 JUL 2023	2.8-1	24 FEB 2022
0.6-1	24 FEB 2022	2.8-2	24 FEB 2022
0.6-2	24 FEB 2022	2.8-3	24 FEB 2022
		2.8-4	24 FEB 2022
GEN1		2.8-5	21 APR 2022
1.1-1	24 FEB 2022	2.9-1	24 FEB 2022
1.2-1	24 FEB 2022	2.10-1	24 FEB 2022
1.2-2	24 FEB 2022		
1.3-1	16 JUN 2022	GEN3	
1.7-1	24 FEB 2022	3.1-1	24 FEB 2022
1.7-2	24 MAR 2022	3.2-1	16 JUN 2022
		3.3-1	24 FEB 2022
GEN2		3.3-2	24 FEB 2022
2.1-1	24 FEB 2022	3.4-1	24 FEB 2022
2.1-2	24 FEB 2022	3.4-2	24 FEB 2022
2.2-1	24 FEB 2022	3.4-3	24 FEB 2022
2.2-2	19 MAY 2022	3.5-1	24 FEB 2022
2.2-3	26 JAN 2023	3.5-2	26 JAN 2023
2.2-4	26 JAN 2023	3.6-1	19 MAY 2022
2.2-5	26 JAN 2023	3.6-2	24 FEB 2022
2.2-6	24 FEB 2022	3.6-3	24 FEB 2022
2.2-7	26 JAN 2023	3.6-4	24 FEB 2022
2.2-8	24 FEB 2022	3.6-5	11 AUG 2022
2.3-1	24 FEB 2022		
2.4-1	20 APR 2023	GEN4	
2.4-2	15 JUN 2023	Not used	
2.4-3	15 JUN 2023		
2.5-1	24 FEB 2022		
2.5-2	24 FEB 2022		
2.5-3	11 AUG 2022		
2.5-4	24 FEB 2022		

PAGE	DATE	PAGE	DATE
ENR		ENR2	
ENR0		2.1-1	24 FEB 2022
0.1-1	24 FEB 2022	2.1-2	23 MAR 2023
0.1-2	24 MAR 2022	2.1-3	26 JAN 2023
0.1-3	24 FEB 2022	2.1-4	23 MAR 2023
		2.1-5	23 MAR 2023
ENR1		2.1-6	23 MAR 2023
1.1-1	24 FEB 2022	2.1-7	23 MAR 2023
1.1-2	24 MAR 2022	2.2-1	26 JAN 2023
1.1-3	24 FEB 2022	2.2-2	18 MAY 2023
1.1-4	21 APR 2022	2.2-3	11 AUG 2022
1.2-1	24 FEB 2022	2.3-1	24 MAR 2022
1.2-2	24 FEB 2022	2.3-2	24 MAR 2022
1.3-1	21 APR 2022	2.3-3	11 AUG 2022
1.4-1	24 FEB 2022	2.3-4	19 MAY 2022
1.4-2	24 MAR 2022	2.3-5	19 MAY 2022
1.5-1	21 APR 2022	2.3-6	20 APR 2023
1.6-1	24 FEB 2022	2.3-7	18 MAY 2023
1.6-2	24 FEB 2022		
1.7-1	24 FEB 2022	ENR3	
1.7-2	24 FEB 2022	3.0-1	24 FEB 2022
1.7-3	11 AUG 2022	3.1-1	24 FEB 2022
1.8-1	24 FEB 2022	3.2-1	24 FEB 2022
1.9-1	24 FEB 2022	3.3-1	24 FEB 2022
1.9-2	19 MAY 2022	3.3-2	24 FEB 2022
1.9-3	24 FEB 2022	3.3-3	24 FEB 2022
1.9-4	11 AUG 2022	3.3-4	24 FEB 2022
1.9-5	11 AUG 2022	3.3-5	24 FEB 2022
1.9-6	11 AUG 2022	3.3-6	24 FEB 2022
1.10-1	24 FEB 2022	3.3-7	24 FEB 2022
1.10-2	24 FEB 2022	3.3-8	24 FEB 2022
1.10-3	24 FEB 2022	3.3-9	24 FEB 2022
1.10-4	24 FEB 2022	3.3-10	24 FEB 2022
1.10-5	24 FEB 2022	3.3-11	24 FEB 2022
1.10-6	24 FEB 2022	3.3-12	24 MAR 2022
1.10-7	24 FEB 2022	3.3-13	24 MAR 2022
1.10-8	24 FEB 2022	3.3-14	24 MAR 2022
1.10-9	24 FEB 2022	3.3-15	24 FEB 2022
1.10-10	24 FEB 2022	3.3-16	24 FEB 2022
1.10-11	24 FEB 2022	3.3-17	24 FEB 2022
1.10-12	24 FEB 2022	3.3-18	24 MAR 2022
1.10-13	24 FEB 2022	3.3-19	24 FEB 2022
1.10-14	24 FEB 2022	3.3-20	24 FEB 2022
1.10-15	24 FEB 2022	3.3-21	24 FEB 2022
1.10-16	24 FEB 2022	3.3-22	24 FEB 2022
1.10-17	24 FEB 2022	3.4-1	24 FEB 2022
1.10-18	24 FEB 2022	3.4-2	24 FEB 2022
1.10-19	24 FEB 2022	3.4-3	24 FEB 2022
1.10-20	24 FEB 2022	3.4-4	24 FEB 2022
1.11-1	20 APR 2023	3.4-5	20 APR 2023
1.11-2	24 FEB 2022	3.4-6	20 APR 2023

PAGE	DATE	PAGE	DATE
3.4-7	24 FEB 2022	5.1-20	23 MAR 2023
3.4-8	20 APR 2023	5.2-1	24 FEB 2022
3.4-9	24 FEB 2022	5.2-2	24 FEB 2022
3.4-10	24 FEB 2022	5.2-3	24 FEB 2022
3.4-11	24 FEB 2022	5.2-4	24 FEB 2022
3.4-12	24 FEB 2022	5.2-5	24 MAR 2022
3.4-13	18 MAY 2023	5.2-6	24 FEB 2022
3.4-14	24 MAR 2022	5.2-7	16 JUN 2022
3.5-1	24 FEB 2022	5.2-9	24 FEB 2022
3.5-2	16 JUN 2022	5.2-10	24 FEB 2022
3.6-1	24 FEB 2022	5.2-11	24 FEB 2022
		5.3-1	24 FEB 2022
ENR4		5.3-2	24 FEB 2022
4.1-1	23 MAR 2023	5.3-3	24 FEB 2022
4.1-2	23 MAR 2023	5.3-4	24 FEB 2022
4.2-1	24 FEB 2022	5.3-5	16 JUN 2022
4.3-1	24 FEB 2022	5.4-1	19 MAY 2022
4.4-1	24 FEB 2022	5.4-2	24 FEB 2022
4.4-2	24 FEB 2022	5.4-3	24 FEB 2022
4.4-3	24 FEB 2022	5.4-4	03 NOV 2022
4.4-4	24 FEB 2022	5.4-5	14 JUL 2022
4.4-5	24 FEB 2022	5.4-6	14 JUL 2022
4.4-6	24 FEB 2022	5.4-7	14 JUL 2022
4.4-7	03 NOV 2022	5.4-8	14 JUL 2022
4.4-8	24 FEB 2022	5.4-9	14 JUL 2022
4.4-9	24 FEB 2022	5.4-10	14 JUL 2022
4.4-10	24 MAR 2022	5.4-11	14 JUL 2022
4.4-11	24 FEB 2022	5.4-12	14 JUL 2022
4.4-12	24 FEB 2022	5.4-13	14 JUL 2022
4.5-1	15 JUN 2023	5.4-14	18 MAY 2023
		5.4-15	23 FEB 2023
		5.4-16	23 FEB 2023
ENR5		5.4-17	23 FEB 2023
5.1-1	24 FEB 2022	5.4-18	23 FEB 2023
5.1-2	24 FEB 2022	5.5-1	24 FEB 2022
5.1-3	24 FEB 2022	5.5-2	24 FEB 2022
5.1-4	03 NOV 2022	5.5-3	24 FEB 2022
5.1-5	23 MAR 2023	5.5-4	24 FEB 2022
5.1-6	23 MAR 2023	5.5-5	24 FEB 2022
5.1-7	23 MAR 2023	5.5-6	24 FEB 2022
5.1-8	23 MAR 2023	5.5-7	24 FEB 2022
5.1-9	23 MAR 2023	5.5-8	24 FEB 2022
5.1-10	23 MAR 2023	5.5-9	24 FEB 2022
5.1-11	23 MAR 2023	5.5-10	24 FEB 2022
5.1-12	23 MAR 2023	5.5-11	15 JUN 2023
5.1-13	23 MAR 2023	5.6-1	24 FEB 2022
5.1-14	23 MAR 2023	5.6-2	24 FEB 2022
5.1-15	23 MAR 2023	5.6-3	24 MAR 2022
5.1-16	23 MAR 2023		
5.1-17	23 MAR 2023	ENR6	
5.1-18	23 MAR 2023	6.1-1	24 FEB 2022
5.1-19	23 MAR 2023		

PAGE	DATE	PAGE	DATE
AD		AD 2.1-6	24 FEB 2022
AD0		AD 2.1-7	26 JAN 2023
0.1-1	24 FEB 2022	AD 2.1-8	23 MAR 2023
0.1-2	24 FEB 2022	AD 2.1-9	24 FEB 2022
AD1		AD 2.1-10	24 FEB 2022
1.1-1	24 FEB 2022	AD 2.1-11	26 JAN 2023
1.2-1	24 FEB 2022	ADC	13 JUL 2023
1.2-2	23 FEB 2023	AOC-A RWY 10L	13 JUL 2023
AD2		AOC-A RWY 28R	13 JUL 2023
2.0-1	24 FEB 2022	APDC	24 FEB 2022
2.0-2	24 FEB 2022	VAC	24 FEB 2022
2.0-3	24 FEB 2022	NAC	24 FEB 2022
EKKA		Glider Areas in TMA	18 MAY 2023
AD 2.1-1	23 MAR 2023	ILS or LOC RWY 10L	18 MAY 2023
AD 2.1-2	24 FEB 2022	ILS or LOC Z 10L	18 MAY 2023
AD 2.1-3	26 JAN 2023	HI-VORTAC 10L	18 MAY 2023
AD 2.1-4	18 MAY 2023	VORTAC 10L	18 MAY 2023
AD 2.1-5	24 FEB 2022	RNP RWY 10L	18 MAY 2023
AD 2.1-6	24 FEB 2022	WP LIST RWY 10L	26 JAN 2023
AD 2.1-7	23 MAR 2023	ILS or LOC 28R	18 MAY 2023
AD 2.1-8	24 FEB 2022	ILS or LOC Z 28R	18 MAY 2023
AD 2.1-9	26 JAN 2023	HI-VORTAC 28R	18 MAY 2023
AD 2.1-10	24 FEB 2022	VORTAC 28R	18 MAY 2023
ADC	13 JUL 2023	RNP RWY 28R	18 MAY 2023
AOC-A 09R	13 JUL 2023	WP LIST RWY 28R	26 JAN 2023
PATC 27L	13 JUL 2023	EKYT	
VAC	24 FEB 2022	AD 2.1-1	18 MAY 2023
Glider Areas in TMA	26 JAN 2023	AD 2.1-2	18 MAY 2023
ILS or LOC 09R	23 MAR 2023	AD 2.1-3	24 FEB 2022
COPTER ILS or LOC 09R	23 MAR 2023	AD 2.1-4	18 MAY 2023
COPTER TACAN 09R	18 MAY 2023	AD 2.1-5	26 JAN 2023
HI-TACAN 09R	23 MAR 2023	AD 2.1-6	19 MAY 2022
RNP RWY 09R	23 MAR 2023	AD 2.1-7	23 FEB 2023
WP LIST RWY 09R	26 JAN 2023	AD 2.1-8	24 FEB 2022
ILS or LOC 27L	23 MAR 2023	AD 2.1-9	15 JUN 2023
COPTER ILS or LOC 27L	23 MAR 2023	ADC	18 MAY 2023
COPTER TACAN 27L	18 MAY 2023	GMC	15 JUN 2023
HI-TACAN 27L	23 MAR 2023	AOC-A 08L	23 FEB 2023
RNP RWY 27L	23 MAR 2023	PATC 26R	23 FEB 2023
WP LIST RWY 27L	26 JAN 2023	VAC	01 DEC 2022
EKSP		NAC	26 JAN 2023
AD 2.1-1	23 MAR 2023	VFR-08L	26 JAN 2023
AD 2.1-2	24 FEB 2022	VFR-26R	26 JAN 2023
AD 2.1-3	24 FEB 2022	ILS or LOC 08L	23 MAR 2023
AD 2.1-4	24 FEB 2022	HI-TACAN 08L	23 MAR 2023
AD 2.1-5	24 FEB 2022	TACAN 08L (CAT A-B)	23 MAR 2023
		TACAN 08L (CAT C-E)	23 MAR 2023
		RNP RWY 08L	23 MAR 2023
		WP LIST RWY 08L	26 JAN 2023

PAGE	DATE
ILS or LOC 26R (CAT A-B)	23 MAR 2023
ILS or LOC 26R (CAT C-E)	23 MAR 2023
HI-VORTAC 26R	23 MAR 2023
VORTAC 26R (CAT A-B)	23 MAR 2023
VORTAC 26R (CAT C-E)	23 MAR 2023
RNP RWY 26R	23 MAR 2023
WP LIST RWY 26R	26 JAN 2023

AD 3**BGNO**

AD 3.1-1	26 JAN 2023
AD 3.1-2	03 NOV 2022
AD 3.1-3	06 OCT 2022
AD 3.1-4	06 OCT 2022
AD 3.1-5	06 OCT 2022
ADC	26 JAN 2023
NDB RWY 19	26 JAN 2023
RNP RWY 19	26 JAN 2023
WP LIST RWY 19	26 JAN 2023

BGMV

AD 3.1-1	24 FEB 2022
AD 3.1-2	24 FEB 2022
AD 3.1-3	21 APR 2022
AD 3.1-4	06 OCT 2022
AD 3.1-5	24 FEB 2022
AD 3.1-6	26 JAN 2023
ADC	26 JAN 2023
RNP RWY 32	26 JAN 2023
WP LIST RWY 32	26 JAN 2023

CHARTS

LFC 1:500.000 Ed. 46	23 MAR 2023
ANC 1:250.000 CPH AREA	20 APR 2023

INTENTIONALLY LEFT BLANK

3. Corrections to TFC-L Charts		
Affected Chart	Location	Corr.
None.		

BLANK

KARUP (EKKA) ARP: 56°17.85N 009°07.48E AD ELEV: 171 FT KARUP APP: 120.425 269.275 KARUP TWR: 119.575 353.575 KARUP ATIS: 120.575

RWY SLOPE:
All runways: Less than 1%

OBSTACLES:
All obstacles are marked by day and night

SECONDARY POWER SUPPLY:
Yes, RWY 27L switch-over time during CAT II: 1 SEC, otherwise 15 sec.

ABN:
NIL

ARRESTER CABLES:
Arrester cables for fighters may be suspended across runways. Always disengaged in the approach end. Approach end arrestment on request only. Cables RWY 09L/27R on 30 min. request.

GRASS RWY:
Grass RWY 09-27 2789 x 147 FT is established on either the northern or southern half of the grass strip, depending on surface conditions. Marked with day markings.

DATUM:
Dimensions and distances in FT.

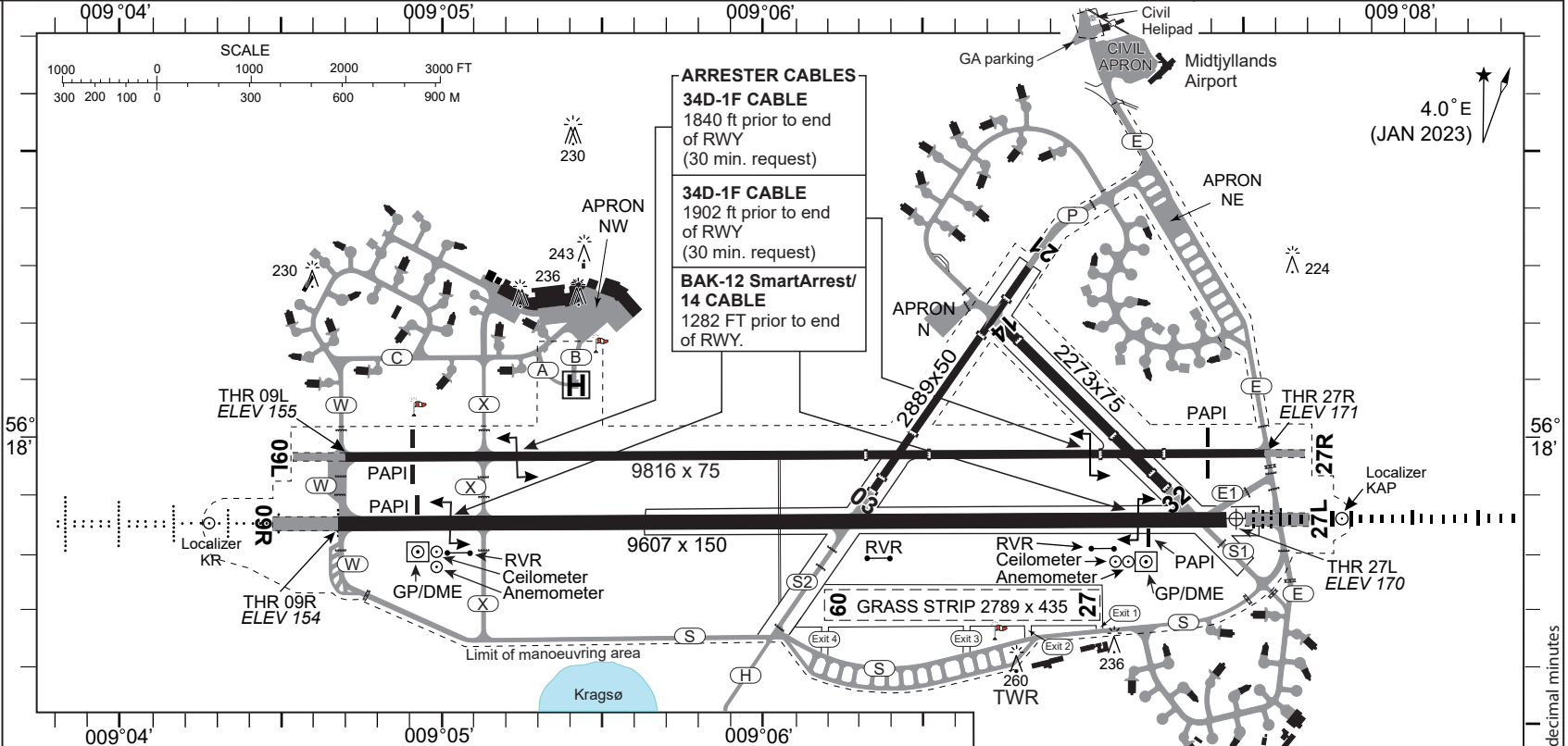

RWY	TRUE BRG	THR PSN	THR elevation Highest ELEV of TDZ of precision APP RWY	Streight and surface of RWY and SWY	DECLARED DISTANCES					APCH and RWY LGT							
					PSN TWY	TORA (ft)	TODA (ft)	ASDA (ft)	LDA (ft)	APCH	THR	TDZ	PAPI	Edge	End	SWY	
09R	089.3°	561749.74N 0090438.39E	THR 154.00	PCN 75 F/C/W/T Asphalt/ concrete Composite construction	W	8103	8103	8848	10352	9607	3000 ft NATO STD White	Green	NIL	3.00°	9863 ft LIH White	Red	Red
			TDZ 160.00														
27L	269.3°	561750.85N 0090728.66E	THR 170.00	PCN 75 F/C/W/T Asphalt/ concrete Composite construction	THR E1	9166	9166	9921	10352	9607	3000 ft CAT II	Green	3000 ft White	3.00°	9863 ft LIH White	Red	Red
			TDZ 170.00														
09L	089.3°	561756.70N 0090439.44E	THR 155.00	PCN 120 F/B/W/T Asphalt/ concrete Composite construction	W	9816	9816	10389	10389	9816	NIL	Green LIL	NIL	2.75°	9747 ft LIL Yellow	Red LIL	NIL
			-														
27R	269.3°	561757.84N 0090733.43E	THR 171.00	PCN 120 F/B/W/T Asphalt/ concrete Composite construction	E	9816	9816	10282	10282	9816	NIL	Green LIL	NIL	2.75°	9747 ft LIL Yellow	Red LIL	NIL
			-														

RWY	TRUE BRG	Dimension	Surface	THR coordinates
21	214°	2889 x 50 ft	PCN 90 F/C/W/T Asphalt/concrete	561817.29N 0090648.64E
14	135°	2273 x 75 ft	PCN 101 F/C/W/T Asphalt/concrete	561809.92N 0090645.99E
32	315°	2273 x 75 ft	PCN 101 F/C/W/T Asphalt/concrete	561754.26N 0090714.80E
09	089°	2789 x 147 ft	Grass	
27	269°	2789 x 147 ft	Grass	

CIR	RWY	GS	TCH	OTCH	RPI	CAT	MINIMA (MIPS)
	ALL					A	670 - 1.5 499 (500-1.6)
						B	680 - 1.6 509 (600-1.6)
						C	850 - 2.4 679 (700-2.4)
						D	880 - 3.6 709 (700-3.6)
						E	1120 - 3.6 949 (1000-4.8)

OTHER RUNWAYS				
RWY	TRUE BRG	Dimension	Surface	THR coordinates
03	034°	2889 x 50 ft	PCN 90 F/C/W/T Asphalt/concrete	561753.78N 0090619.75E
21	214°	2889 x 50 ft	PCN 90 F/C/W/T Asphalt/concrete	561817.29N 0090648.64E
14	135°	2273 x 75 ft	PCN 101 F/C/W/T Asphalt/concrete	561809.92N 0090645.99E
32	315°	2273 x 75 ft	PCN 101 F/C/W/T Asphalt/concrete	561754.26N 0090714.80E
09	089°	2789 x 147 ft	Grass	
27	269°	2789 x 147 ft	Grass	

TWY width: TWY E1, TWY S, TWY X: 40 FT. Other TWY's: 50 - 80 FT. TWY lighting: BLUE EDGE. RGL for RWY 09R/27L.

Helipad position: 56°18.07'N 009°05.38'E. PCN 29 F/C/W/T

CHANGES HOLDING POINT ADDED TWY P.

AIR COMMAND DENMARK - MIL AIM 13 JUL 2023

ELEV in FT
Distance in FT
Magnetic Variation 4.0° E (JAN 2023)
Order of accuracy: Horizontally 1 FT, Vertically 1 FT

AERODROME OBSTACLE CHART - ICAO

TYPE A (OPERATING LIMITATIONS)

KARUP, Denmark
RWY 09R

LEGEND		AMENDMENT RECORD		
Identification number	⑤	No.	Date	Entered by
Tree	*			
Group of trees	⊠			

Date of survey: 03/2019

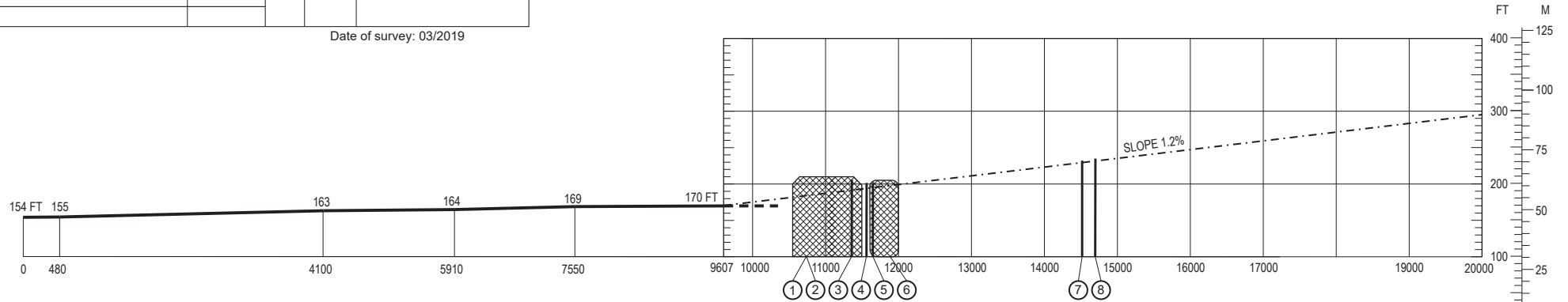

DECLARED DISTANCES	
TAKE OFF RUN AVAILABLE	RWY 09R 9607
TAKE OFF DISTANCE AVAILABLE	9607
ACCELERATE STOP DISTANCE AVAILABLE	10352
LANDING DISTANCE AVAILABLE	9607

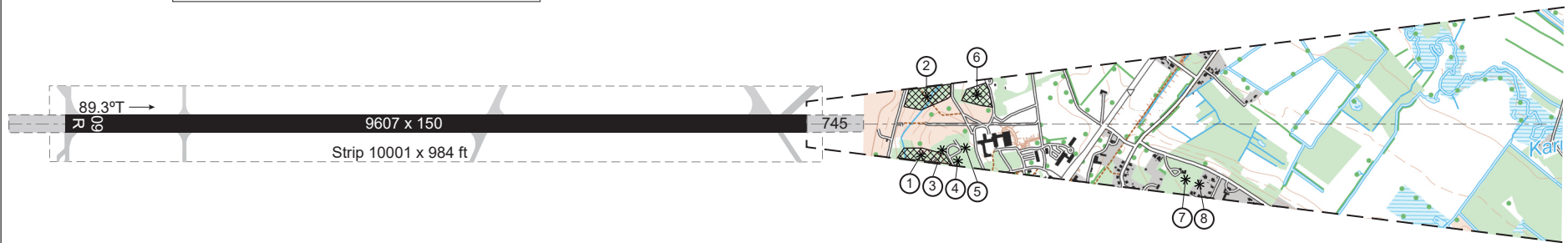

HORIZONTAL SCALE 1 : 25.000

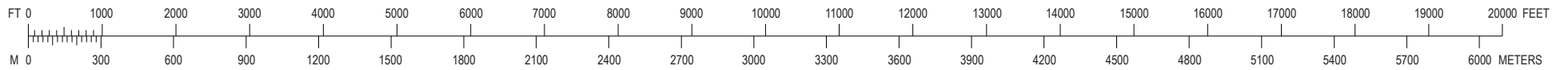

CHANGES: EDITORIAL, MAG. VAR.

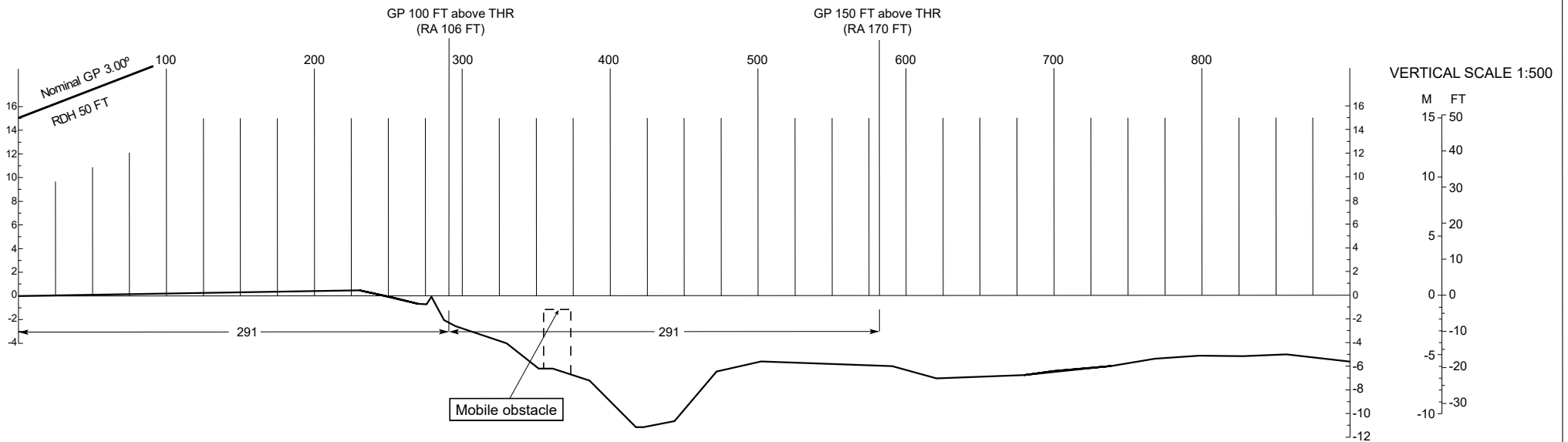
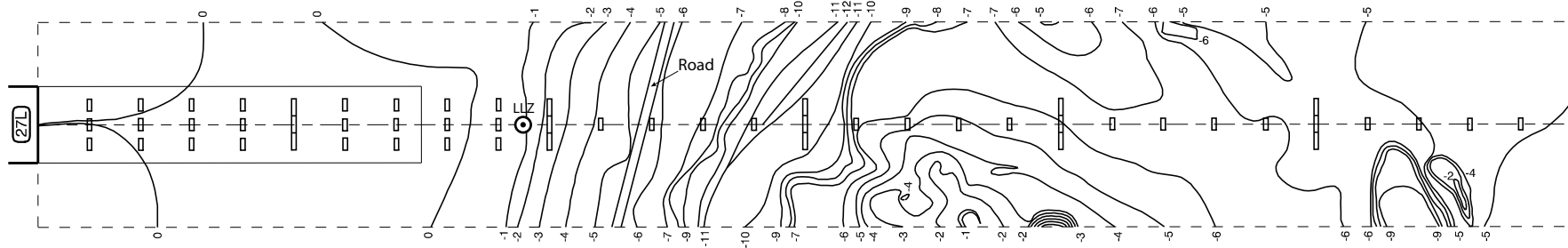

- Centerline profile
- Contour
- Pole, tower, chimney, antenna
- Approach lights
- Traffic
- Deviation at least ± 3 meters from centerline profile

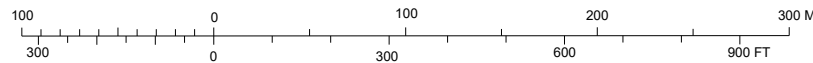

Contours and heights are related to threshold elevation
 Contours and heights in meters unless otherwise stated
 RA = Radio altimeter

SKRYDSTRUP (EKSP)	ARP: 55°13.53N 009°15.84E	AD ELEV: 141 FT	SKRYDSTRUP APP: SKRYDSTRUP TWR:	124.100 315.100 118.275 286.375	SKRYDSTRUP ATIS: 133.900
--------------------------	---------------------------	-----------------	------------------------------------	------------------------------------	--------------------------

RWY SLOPE:
RWY 10L/28R: Less than 1%
RWY 10R/28L: Less than 1%

OBSTACLES:
All obstacles are marked by day and night.

SECONDARY POWER SUPPLY:
Yes. switch-over time 15 sec.

ABN:
NIL

ARRESTER CABLES:
Arrester cables for fighters may be suspended across runways. Always disengaged in the approach end.
Back up cables in the SWY of RWY 10L/28R are always positioned for engagement. Usable in departure direction only. **WARNING: Landing short of runway threshold with hook down may cause substantial damage to the aircraft.**

DATUM: WGS 84
Dimensions and distances in FT

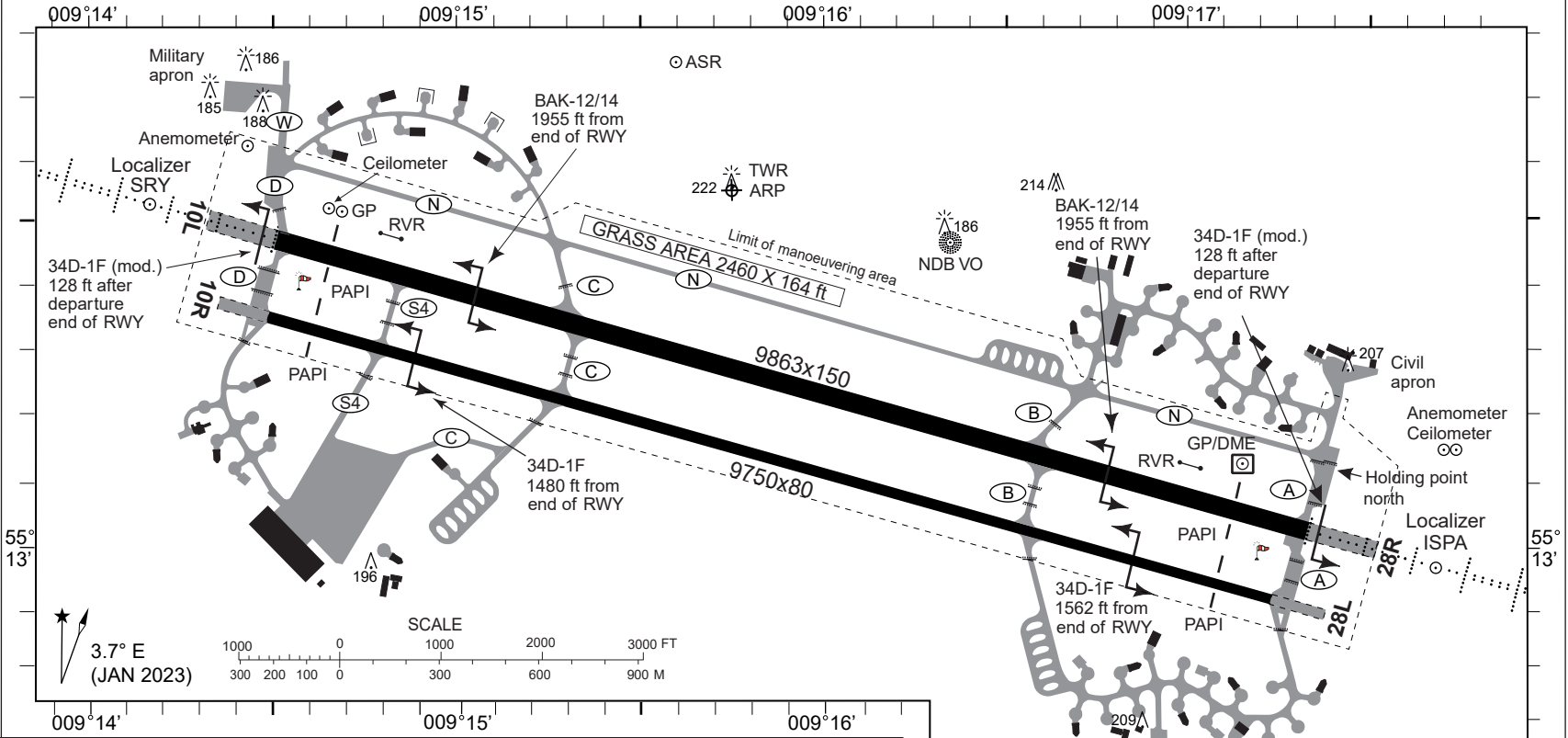

RWY	TRUE BRG	THR PSN	THR elevation Highest ELEV of TDZ of precision APP RWY	Streight and surface of RWY and SWY	DECLARED DISTANCES					APCH and RWY LGT					CIR	RWY	GS	TCH	OTCH	RPI	CAT	MINIMA (MIPS)	
					PSN TWY	TORA (ft)	TODA (ft)	ASDA (ft)	LDA (ft)	APCH	THR	PAPI	Edge	End									SWY
10L	105.44°	551328.56N 0091438.19E	THR 126.00 TDZ 127.00	PCN 90 F/B/W/T Asphalt/ concrete	D	9863	9863	10597	9863	900 M NATO STD White	Green	3.00°	9863 ft LIH White	Red	Red								
					C	7273	7273	8007															
28R	285.44°	551302.76N 0091722.11E	THR 141.00 TDZ 141.00		A	9863	9863	10600	9863	900 M NATO STD White	Green	3.00°	9863 ft LIH White	Red	Red								
				B	7421	7421	8158																
					C	2837	2837	3574															
10R	105.44°	551321.71N 0091435.91E	THR 124.00	PCN 77 F/B/W/T Asphalt/ concrete	D	9747	9747	10237	9750	NIL	Green Wing bars	3.00°	9747 ft LIL White	Red Wing bars	NIL								
					C	7066	7066	7556															
					B	2358	2358	2848															
28L	285.44°	551256.12N 0091717.95E	THR 139.00		A	9747	9747	10237	9750	NIL	Green Wing bars	3.00°	9747 ft LIL White	Red Wing bars	NIL								
				B	7457	7457	5247																
					C	2759	2759	3249															

GRASS AREA 2460 X 164 FT may be used by light propeller aircraft, helicopters and gliders.

TWY width: TWY D north of RWY 10L/28R to military apron: 75 FT.
Other TWYs: 50 FT.
TWY lighting: BLUE EDGE.

CHANGES: EDITORIAL

AIR COMMAND DENMARK - MIL AIM 13 JUL 2023

ELEV in FT
Distance in FT
Magnetic Variation 3.7° (JAN 2023)
Order of accuracy: Horizontally 1 FT, Vertically 1 FT

AERODROME OBSTACLE CHART - ICAO

TYPE A (OPERATING LIMITATIONS)

SKRYDSTRUP, Denmark
RWY 10L

LEGEND		AMENDMENT RECORD		
Identification number	⑮	No.	Date	Entered by
Tree or Shrub	*			
Line of trees	*.....*			
Group of trees / wooded hill	⊛			
Pole, tower, spire, antenna etc.	○			
Mobile obstacle	←-----→			
Transmission line or overhead cable	—T—			

Date of survey: 12/2017

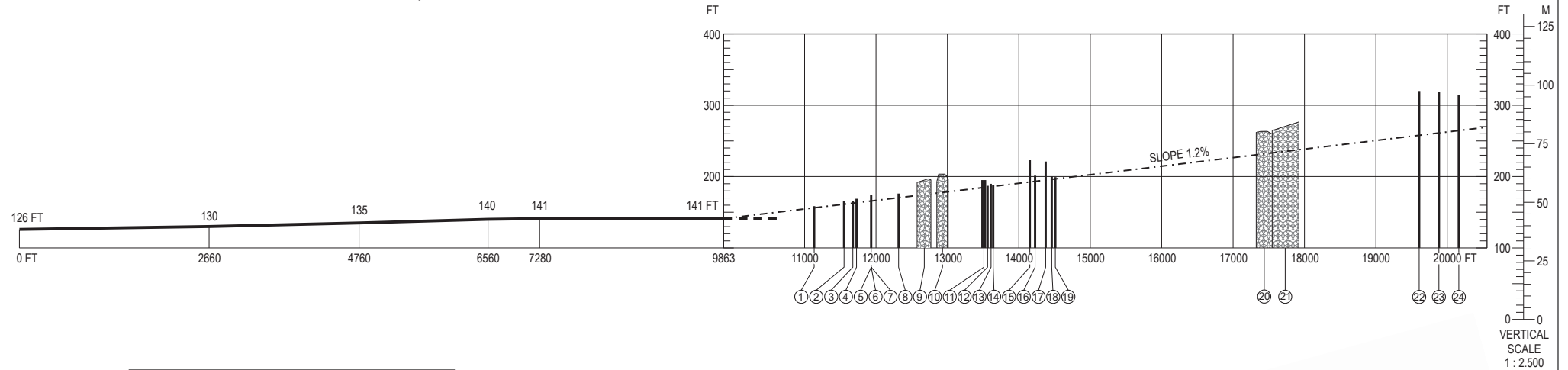

DECLARED DISTANCES	
TAKE OFF RUN AVAILABLE	RWY 10L 9863
TAKE OFF DISTANCE AVAILABLE	9863
ACCELERATE STOP DISTANCE AVAILABLE	10597
LANDING DISTANCE AVAILABLE	9863

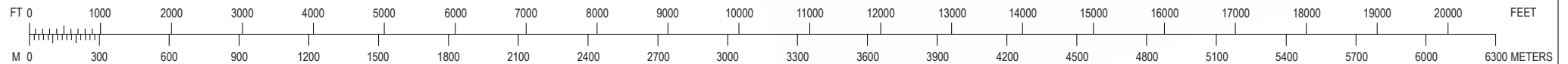
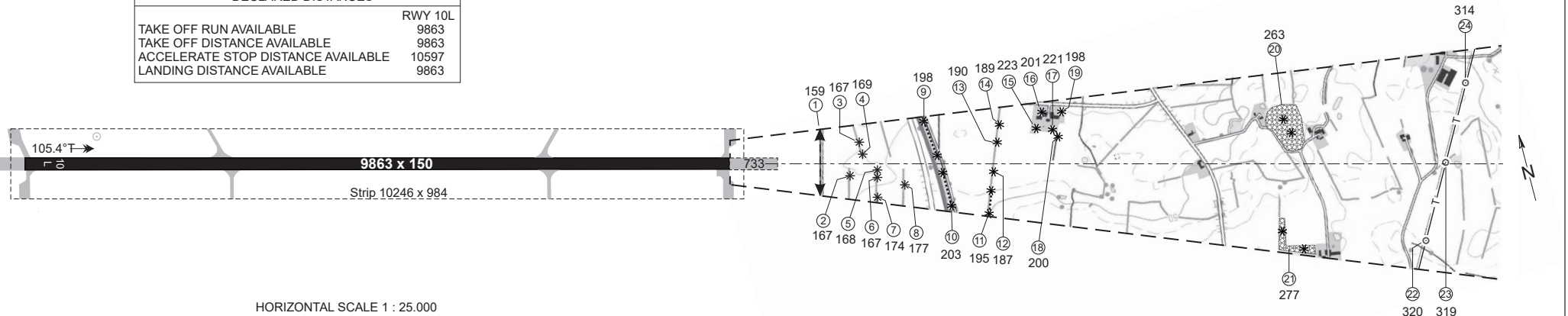

CHANGES EDITORIAL MAG. VAR.

ELEV in FT
Distance in FT
Magnetic Variation 3.7° (JAN 2023)
Order of accuracy: Horizontally 1 FT, Vertically 1 FT

AERODROME OBSTACLE CHART - ICAO

TYPE A (OPERATING LIMITATIONS)

SKRYDSTRUP, Denmark
RWY 28R

LEGEND		AMENDMENT RECORD		
Identification number	⑮	No.	Date	Entered by
Tree or Shrub	*			

Date of survey: 12/2017

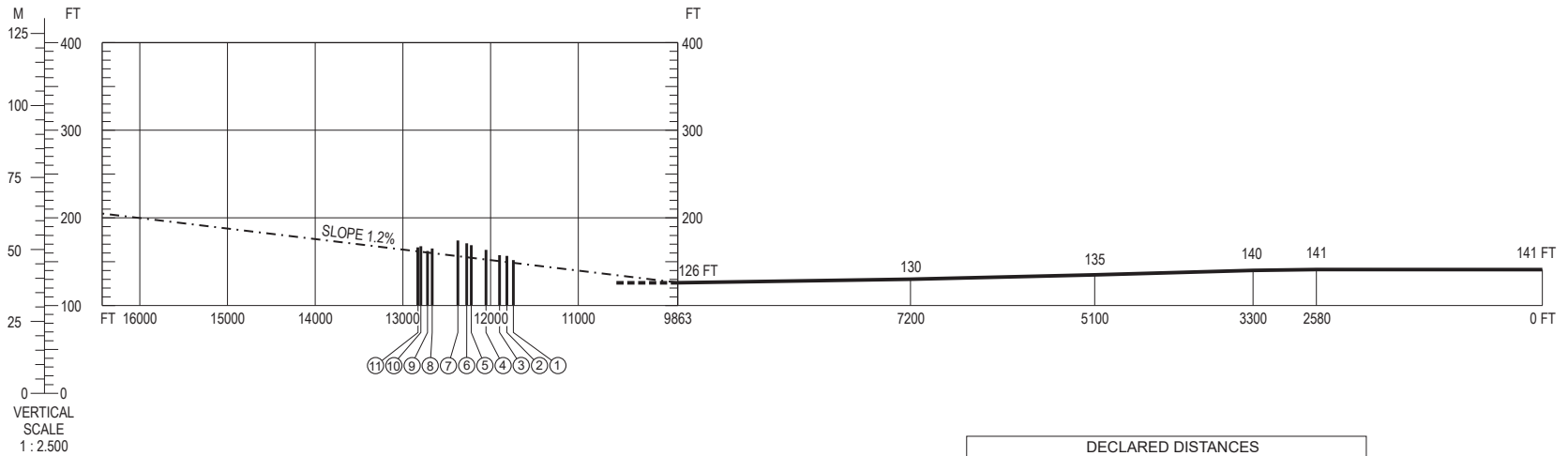

DECLARED DISTANCES	
TAKE OFF RUN AVAILABLE	RWY 28R 9863
TAKE OFF DISTANCE AVAILABLE	9863
ACCELERATE STOP DISTANCE AVAILABLE	10600
LANDING DISTANCE AVAILABLE	9863

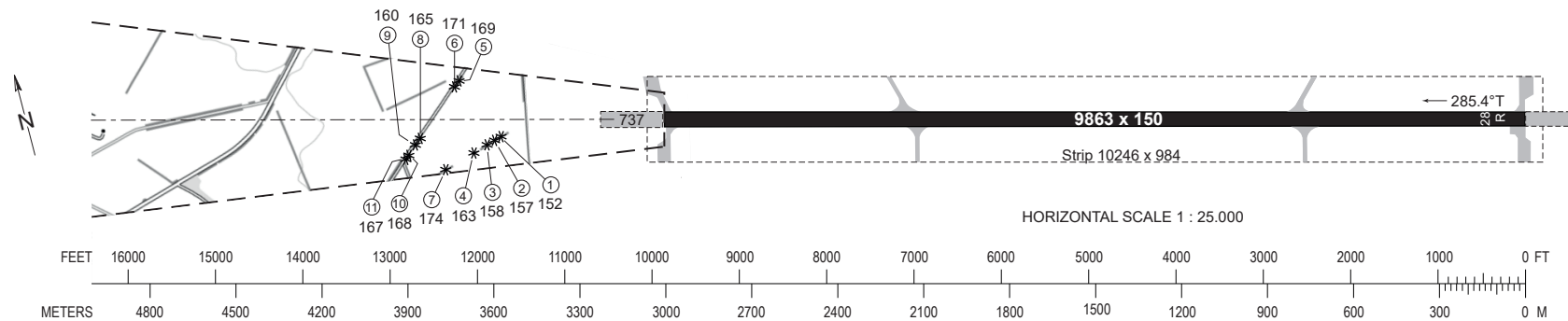

CHANGES: EDITORIAL, MAG. VAR.

